



RXM-GPS-SG



WIRELESS MADE SIMPLE

SG SERIES GPS RECEIVER MODULE DATA GUIDE

DESCRIPTION

The SG Series GPS receiver module is a self-contained high-performance GPS receiver with an on-board LNA and SAW filter. Based on the SiRFstar III chipset, it provides exceptional sensitivity, even in dense foliage and urban canyons. The module's very low power consumption helps maximize runtimes in battery powered applications. With over 200,000 effective correlators, the SG Series receiver can acquire and track up to 20 satellites simultaneously in just seconds, even at the lowest signal levels. Housed in a compact reflow-compatible SMD package, the receiver requires no programming or

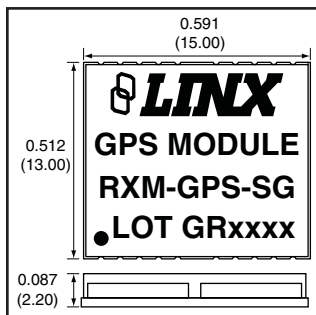

Figure 1: Package Dimensions

additional RF components (except an antenna) to form a complete GPS solution. Five GPIOs are easily configured through simple serial commands. These features, along with the module's standard NMEA data output, make the SG Series easy to integrate, even by engineers without previous RF or GPS experience.

FEATURES

- SiRF Star III chipset
- 200,000+ correlators
- Low power consumption (46mW)
- High sensitivity (-159dBm)
- 20 channels
- Fast TTFB at low signal levels
- Battery-backed SRAM
- 5 User Definable GPIOs
- No programming necessary
- No external RF components needed (except an antenna)
- No production tuning
- Direct serial interface
- Power down feature
- Compact surface-mount package
- Manual or reflow compatible
- RoHS compliant

APPLICATIONS INCLUDE

- Positioning and Navigation
- Location and Tracking
- Security/Loss-Prevention
- Surveying
- Logistics
- Fleet Management

ORDERING INFORMATION

PART #	DESCRIPTION
RXM-GPS-SG-x	GPS Receiver Module
MDEV-GPS-SG	Master Development System
x = "T" for Tape and Reel, "B" for Bulk	
Reels are 1,000 pcs.	
Quantities less than 1,000 pcs. are supplied in bulk	

ELECTRICAL SPECIFICATIONS

Parameter	Designation	Min.	Typical	Max.	Units	Notes
POWER SUPPLY						
Supply Voltage	V _{CC}	3.0	–	4.2	VDC	1
Supply Current:	I _{CC}					2
Peak		–	–	46.0	mA	6
Acquisition		–	32	–	mA	6
Tracking		–	28	–	mA	6
Standby		–	1.5	–	mA	6
Backup Battery Voltage	V _{BAT}	1.3	–	6.0	VDC	–
Backup Battery Current	I _{BAT}	–	10	–	µA	–
2.85V Output Voltage	V _{OUT}	2.79	2.85	2.91	VDC	–
2.85V Output Current	I _{OUT}	–	–	30	mA	3
Output Logic Low Voltage	V _{OL}	–	–	0.25*V _{OUT}	VDC	–
Output Logic High Voltage	V _{OH}	0.75*V _{OUT}	–	–	VDC	–
Output Logic Low Current	I _{OL}	–	2	–	mA	–
Output Logic High Current	I _{OH}	–	2	–	mA	–
Input Logic Low Voltage	V _{IL}	-0.3	–	0.3*V _{OUT}	VDC	–
Input Logic High Voltage	V _{IH}	0.7*V _{OUT}	–	3.6	VDC	–
Input Logic Low Current	I _{IL}	-60	–	20	µA	–
With Pull-down		–	–	60	µA	–
Input Logic High Current	I _{IH}	-60	–	20	µA	–
With Pull-down		–	–	60	µA	–
Input Capacitance	C _{IN}	–	–	4	pF	–
Output Capacitance	C _{OUT}	–	–	4	pF	4
LNA SECTION						
Insertion Power Gain	IS ₂₁ ²	–	18	–	dB	5
Noise Figure	NF	–	0.9	–	dB	5
ANTENNA PORT						
RF Input Impedance	R _{IN}	–	50	–	Ω	–
ENVIRONMENTAL						
Operating Temperature Range		–30	–	+85	°C	–
Storage Temperature Range		-40	25	+85	°C	–
RECEIVER SECTION						
Receiver Sensitivity						
Tracking		–	-159	–	dBm	–
Cold Start		–	-144	–	dBm	–
Acquisition Time						
Hot Start (Open Sky)		–	–	2	S	–
Hot Start (Indoor)		–	–	15	S	–
Cold Start		–	35	–	S	–
Position Accuracy						
Autonomous		–	–	10	m	–
SBAS		–	–	5	m	–
Altitude		–	–	60,000	ft	–
Velocity		–	–	1,000	Knots	–
Chipset	SiRF Star III, GSC3f/LPx 7990					
Firmware Version	GSW3.5.0_3.5.00.00-SDK-3EP2.01A					
Frequency	L1 1575.42MHz, C/A Code					
Channels	20					
Update Rate	1Hz					
Protocol Support	NMEA 0183 ver 3.0, SiRF Binary					

Table 1: SG Series Receiver Specifications

Notes:

- I_{OUT} = 0
- V_{CC} = 3.3V, I_{OUT} = 0
- V_{CC} = 3.3V
- Output buffer
- At 25°C
- With passive antenna. Active antennas will increase current consumption.

ABSOLUTE MAXIMUM RATINGS

Supply Voltage V _{CC}	+6.5	VDC
Input Battery Backup Voltage	+7.0	VDC
2.85V Output Current	50	mA
Operating Temperature	-30 to +85	°C
Storage Temperature	-40 to +125	°C
Soldering Temperature	+225°C for 10 seconds	

NOTE Exceeding any of the limits of this section may lead to permanent damage to the device. Furthermore, extended operation at these maximum ratings may reduce the life of this device.

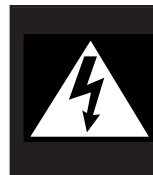

CAUTION

This product incorporates numerous static-sensitive components. Always wear an ESD wrist strap and observe proper ESD handling procedures when working with this device. Failure to observe this precaution may result in module damage or failure.

ONLINE RESOURCES



www.linxtechnologies.com

- Latest News
- Data Guides
- Application Notes
- Knowledgebase
- Software Updates



If you have questions regarding this or any LinX product make www.linxtechnologies.com your first stop. Day or night, the LinX website gives you instant access to the latest information regarding the products and services of LinX. It's all here: manual and software updates, application notes, a comprehensive knowledgebase, FCC information, and much more. Here you will find the answers you need arranged in an intuitive format. Be sure to visit often!

PIN ASSIGNMENTS

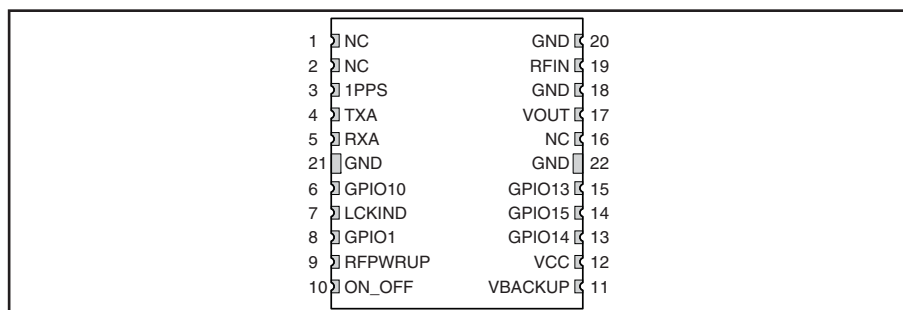

Figure 2: SG Series Receiver Pinout (Top View)

PIN DESCRIPTIONS

Pin #	Name	I/O	Description
1, 2, 16	NC	-	No Connect. No electrical connection.
3	1PPS	O	Pulse per second (1uS pulse)
4	TXA	O	Serial output for channel A (default NMEA)
5	RXA	I	Serial input for channel A (default NMEA)
6	GPIO10	I/O	General Purpose I/O
7	LCKIND	O	Lock Indicator
8	GPIO1	I/O	General Purpose I/O, 100kΩ pull down
9	RFPWRUP	O	Indicate power state
10	ON_OFF	I	Edge triggered soft on/off request. Should only be used to wake up the module when the RFPWRUP line is low.
11	VBACKUP	P	Backup battery supply voltage. This line must be powered to enable the module.
12	VCC	P	Supply Voltage
13	GPIO14	I/O	General Purpose I/O, 100kΩ pull up
14	GPIO15	I/O	General Purpose I/O, 100kΩ pull up
15	GPIO13	I/O	General Purpose I/O
17	VOUT	P	2.85V Linear regulator power output
18,20-22	GND	P	Ground
19	RFIN	I	GPS RF signal input

A BRIEF OVERVIEW OF GPS

The Global Positioning System (GPS) is a U.S.-owned utility that freely and continuously provides positioning, navigation, and timing (PNT) information. Originally created by the U.S. Department of Defense for military applications, the system was made available without charge to civilians in the early 1980s. The global positioning system consists of a nominal constellation of 24 satellites orbiting the earth at about 12,000 nautical miles in height. The pattern and spacing of the satellites allow at least four to be visible above the horizon from any point on the Earth. Each satellite transmits low power radio signals which contain three different bits of information; a pseudorandom code identifying the satellite, ephemeris data which contains the current date and time as well as the satellite's health, and the almanac data which tells where each satellite should be at any time throughout the day.

A GPS receiver such as the Linx SG Series GPS module receives and times the signals sent by multiple satellites and calculates the distance to each satellite. If the position of each satellite is known, the receiver can use triangulation to determine its position anywhere on the earth. The receiver uses four satellites to solve for four unknowns; latitude, longitude, altitude, and time. If any of these factors is already known to the system, an accurate position (Fix) can be obtained with fewer satellites in view. Tracking more satellites improves calculation accuracy. In essence, the GPS system provides a unique address for every square meter on the planet.

A faster Time To First Fix (TTFF) is also possible if the satellite information is already stored in the receiver. If the receiver knows some of this information, then it can accurately predict its position before acquiring an updated position fix. For example, aircraft or marine navigation equipment may have other means of determining altitude, so the GPS receiver would only have to lock on to three satellites and calculate three equations to provide the first position fix after power-up.

TTFF is often broken down into three parts:

Cold: A cold start is when the receiver has no accurate knowledge of its position or time. This happens when the receiver's internal Real Time Clock (RTC) has not been running or it has no valid ephemeris or almanac data. In a cold start, the receiver takes 35 to 40 seconds to acquire its position. If new almanac data is required, this may take up to 15 minutes (see page 9 for more details).

Warm or Normal: A typical warm start is when the receiver has valid almanac and time data and has not significantly moved since its last valid position calculation. This happens when the receiver has been shut down for more than 2 hours, but still has its last position, time, and almanac saved in memory, and its RTC has been running. The receiver can predict the location of the current visible satellites and its location; however, it needs to wait for an ephemeris broadcast (every 30 seconds) before it can accurately calculate its position.

Hot or Standby: A hot start is when the receiver has valid ephemeris, time, and almanac data. This happens when the receiver has been shut down for less than 2 hours and has the necessary data stored in memory with the RTC running. In a hot start, the receiver takes 1 to 2 seconds to acquire its position. The time to calculate a fix in this state is sometimes referred to as Time to Subsequent Fix or TTFSF.

MODULE DESCRIPTION

By default, the SG Series will operate in full power mode. However, it also has a built-in power control mode called Adaptive Trickle Power mode. The module is based on the SiRFstar III low power chipset, which consumes significantly less power than competitive products while providing exceptional performance even in dense foliage and urban canyons. The module includes an internal SAW filter and LNA, so no external RF components are needed other than an antenna. The simple serial interface and industry standard NMEA protocol make integration of the SG Series receiver into an end product or system extremely straightforward.

The module's high-performance RF architecture allows it to receive GPS signals that are as low as -159dBm. With over 200,000 effective correlators, the SG Series can track up to 20 satellites at the same time. Once locked onto the visible satellites, the receiver calculates the range to the satellites and determines its position and the precise time. It then outputs the data through a standard serial port using several standard NMEA protocol formats.

The GPS core handles all of the necessary initialization, tracking, and calculations autonomously, so no programming is required. The RF section is optimized for low level signals, and requires no production tuning of any type.

ANTENNA CONSIDERATIONS

The SG Series module is designed to utilize a wide variety of external antennas. The module has a regulated power output which simplifies the use of GPS antenna styles which require external power. This allows the designer great flexibility, but care must be taken in antenna selection to ensure optimum performance. For example, a handheld device may be used in many varying orientations so an antenna element with a wide and uniform pattern may yield better overall performance than an antenna element with high gain and a correspondingly narrower beam. Conversely, an antenna mounted in a fixed and predictable manner may benefit from pattern and gain characteristics suited to that application. Evaluating multiple antenna solutions in real-world situations is a good way to rapidly assess which will best meet the needs of your application.

For GPS, the antenna should have good right hand circular polarization characteristics (RHCP) to match the polarization of the GPS signals. Ceramic patches are the most commonly used style of antenna, but there are many different shapes, sizes and styles of antennas available. Regardless of the construction, they will generally be either passive or active types. Passive antennas are simply an antenna tuned to the correct frequency. Active antennas add a Low Noise Amplifier (LNA) after the antenna and before the module to amplify the weak GPS satellite signals.

For active antennas, the VOUT line can provide 2.85V at 30mA to power the external LNA. A 300 ohm ferrite bead should be used to connect this line to the RFIN line. This bead will prevent the RF from getting into the power supply, but will allow the DC voltage onto the RF trace to feed into the antenna. A series capacitor inside the module prevents this DC voltage from affecting the bias on the module's internal LNA.

Maintaining a 50 ohm path between the module and antenna is critical. Errors in layout can significantly impact the module's performance. Please review the layout guidelines elsewhere in this guide carefully to become more familiar with these considerations.

BACKUP BATTERY

The module is designed to work with a backup battery that keeps the SRAM memory and the RTC powered when the RF section and the main GPS core are powered down. This enables the module to have a faster Time To First Fix (TTFF) when the it is powered back on. The memory and clock pull about 10 μ A. This means that a small lithium battery is sufficient to power these sections. This significantly reduces the power consumption and extends the main battery life while allowing for fast position fixes when the module is powered back on.

POWER SUPPLY REQUIREMENTS

The module requires a clean, well-regulated power source. While it is preferable to power the unit from a battery, it can operate from a power supply as long as noise is less than 20mV. Power supply noise can significantly affect the receiver's sensitivity, therefore providing clean power to the module should be a high priority during design. Bypass capacitors should be placed as close as possible to the module. The values should be adjusted depending on the amount and type of noise present on the supply line.

THE 1PPS OUTPUT

The 1PPS line outputs 1 pulse per second on the rising edge of the GPS second when the receiver has an over-solved navigation solution from five or more satellites. The pulse has a duration of 1 μ S and an accuracy of about 1 μ S from the GPS second. This line is low until the receiver acquires an over-solved navigation solution (a lock on more than 4 satellites). The GPS second is based on the atomic clocks in the GPS satellites, which are monitored and set to Universal Time master clocks. This output and the time calculated from the GPS satellite transmissions can be used as a clock feature in an end product.

GENERAL PURPOSE I/O

The SG Series module has five general purpose I/Os (GPIOs) that are configured using four simple input messages: set the I/Os as inputs or outputs, read the states of the inputs, write the states of the outputs, and read the current configuration and states of all of the GPIOs. This offers the system additional lines without increasing the size or load on the user's microcontroller. Refer to the NMEA Input Messages section for details on the commands.

THE LOCK INDICATOR LINE

The Lock Indicator line outputs a series of 100mS pulses with a 50% duty cycle when the module is searching for a fix. Once the receiver acquires a solution, the line outputs a single 100mS pulse every second. This line can be connected to a microcontroller to monitor the state of the module or connected to an LED as a visual indicator.

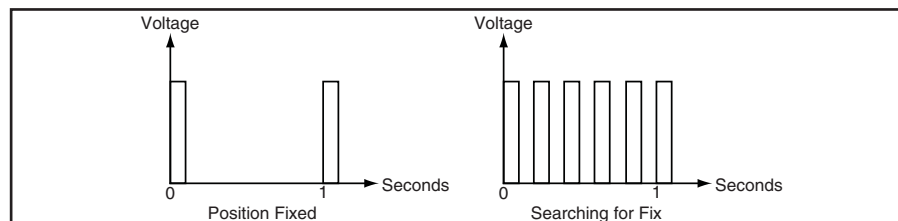

Figure 3: SG Series Lock Indicator Signals

POWER CONTROL

The SG Series has a built-in power control mode called Adaptive Trickle Power mode. In this mode, the receiver will power on at full power to acquire and track satellites and obtain satellite data. It then powers off the RF stage and only uses its processor stage (CPU) to determine a position fix (which takes about 160mS). Once the fix is obtained, the receiver goes into a low power standby state. After a user-defined period of time, the receiver wakes up to track the satellites for a user-defined period of time, updates its position using the CPU only, and then resumes standby. The initial acquisition time is variable, depending on whether it is a cold start or assisted, but a maximum acquisition time is definable. This cycling of power is ideal for battery-powered applications since it significantly reduces the amount of power consumed by the receiver while still providing similar performance to the full power mode.

In normal conditions, this mode provides a fixed power savings, but under poor signal conditions, the receiver returns to full power to improve performance. The receiver sorts the satellites according to signal strength and if the fourth satellite is below 26dB-Hz, then the receiver switches to full power. Once the fourth satellite is above 30dB-Hz, the receiver returns to Adaptive Trickle Power mode.

For optimum performance, SiRF recommends cycle times of 300mS track to 1S interval or 400mS track to 2S interval. CPU time is about 160mS to compute the navigation solution and empty the UART. There are some situations in which the receiver stays in full power mode. These are: to collect periodic ephemeris data, to collect periodic ionospheric data, to perform RTC convergence, and to improve the navigation result. Depending on states of the power management, the receiver will be in one of three system states:

Full Power State

All RF and baseband circuitry are fully powered. There is a difference in power consumption during acquisition mode and tracking mode. Acquisition requires more processing, so it consumes more power. This is the initial state of the receiver and it stays in this state until a reliable position solution is achieved.

CPU Only State

This state is entered when the satellite measurements have been collected but the navigation solution still needs to be computed. The RF and DSP processing are no longer needed and can be turned off.

Stand-By State

In this state, the RF section is completely powered off and the clock to the baseband is stopped. About 1mA of current is drawn in this state for the internal core regulator, RTC and battery-backed RAM. The receiver enters this state when a position fix has been computed and reported.

The table below shows the RFPWRUP and Vout conditions in each power state.

Power State	RFPWRUP	VOUT
Full power	H	Enabled
CPU only	H	Enabled
Stand by	L	Enabled

Table 2: RFPWRUP and VOUT conditions

TYPICAL APPLICATIONS

Figure 4 shows a circuit using the GPS module with a passive antenna.

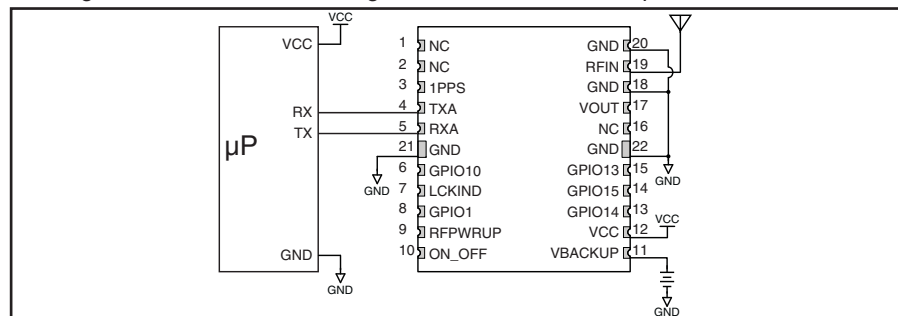

Figure 4: SG Series Module with a Passive Antenna

Figure 5 shows a circuit using the GPS module with an active antenna.

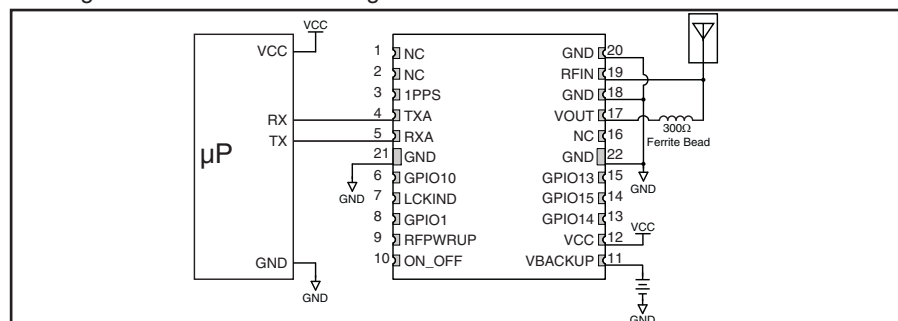

Figure 5: SG Series Module with an Active Antenna

SLOW START TIME

The most critical factors in start time are current ephemeris data, signal strength, and sky view. The ephemeris data describes the path of each satellite as they orbit the earth. This is used to calculate the position of a satellite at a particular time. This data is only usable for a short period of time, so if it has been more than a few hours since the last fix or if the location has significantly changed (a few hundred miles), then the receiver may need to wait for a new ephemeris transmission before a position can be calculated. The GPS satellites transmit the ephemeris data every 30 seconds. Transmissions with a low signal strength may not be received correctly or be corrupted by ambient noise. The view of the sky is important because the more satellites the receiver can see, the faster the fix and the more accurate the position will be when the fix is obtained.

If the receiver is in a very poor location, such as inside a building, urban canyon, or dense foliage, then the time to first fix can be slowed. In very poor locations with poor signal strength and a limited view of the sky with outdated ephemeris data, this could be on the order of several minutes. In the worst cases, the receiver may need to receive almanac data, which describes the health and course data for every satellite in the constellation. This data is transmitted every 15 minutes. If a lock is taking a long time, try to find a location with a better view of the sky and fewer obstructions. Once locked, it is easier for the receiver to maintain the position fix.

PROTOCOLS

LinX GPS modules use the SiRFstar III chipset. This chipset allows two protocols to be used, NMEA-0183 and SiRF Binary. Switching between the two is handled using a single serial command. The NMEA protocol uses ASCII characters for the input and output messages and provides the most common features of GPS development in a small command set. The SiRF Binary protocol uses BYTE data types and allows more detailed control over the GPS receiver and its functionality using a much larger command set. Although both protocols have selectable baud rates, it's recommended that SiRF Binary use baud rates of 38,400bps or higher. For a detailed description of the SiRF Binary protocol, see the SiRF Binary Protocol Reference Manual, available from SiRF Technology, Inc. Although SiRF Binary protocol may be used with the module, Linx only offers tech support for the NMEA protocol.

INTERFACING WITH NMEA MESSAGES

Linx modules default to the NMEA protocol. Output messages are sent from the receiver on the TXA pin and input messages are sent to the receiver on the RXA pin. By default, output messages are sent once every second. Details of each message are described in the following sections.

The NMEA message format is as follows: <Message-ID + Data Payload + Checksum + End Sequence>. The serial data structure defaults to 9,600bps, 8 data bits, 1 stop bit, and no parity bits. Each message starts with a \$ character and ends with a <CR> <LF>. All fields within each message are separated by a comma. The checksum follows the * character and is the last two characters, not including the <CR> <LF>. It consists of two hex digits representing the exclusive OR (XOR) of all characters between, but not including, the \$ and * characters. When reading NMEA output messages, if a field has no value assigned to it, the comma will still be placed following the previous comma. For example, {,04,,,,,2.0,} shows four empty fields between values 04 and 2.0. When writing NMEA input messages, all fields are required, none are optional. An empty field will invalidate the message and it will be ignored.

Reading NMEA output messages:

- Initialize a serial interface to match the serial data structure of the GPS receiver.
- Read the NMEA data from the TXA pin into a receive buffer.
- Separate it into six buffers, one for each message type. Use the characters (\$) and <CR> <LF> as end points for each message.
- For each message, calculate the checksum as mentioned above to compare with the checksum received.
- Parse the data from each message using commas as field separators.
- Update the application with the parsed field values.
- Clear the receive buffer and be ready for the next set of NMEA messages.

Writing NMEA input messages:

- Initialize a serial interface to match the serial data structure of the GPS receiver.
- Assemble the message to be sent with the calculated checksum.
- Transmit the message to the receiver on the RXA pin.

NMEA OUTPUT MESSAGES

The following sections outline the data structures of the various NMEA protocols that are supported by the module. By default, the NMEA commands are output at 9,600bps, 8 data bits, no parity, and 1 stop bit.

GGA – Global Positioning System Fixed Data

The table below contains the values for the following example:

*\$GPGGA,053740.000,2503.6319,N,12136.0099,E,1,08,1.1,63.8,M,15.2,M,,0000*64*

Name	Example	Units	Description
Message ID	\$GPGGA		GGA protocol header
UTC Time	053740		hhmmss.sss
Latitude	2503.6319		ddmm.mmmm
N/S indicator	N		N=north or S=south
Longitude	12136.0099		dddmm.mmmm
E/W Indicator	E		E=east or W=west
Position Fix Indicator	1		See Table 4
Satellites Used	08		Range 0 to 12
HDOP	1.1		Horizontal Dilution of Precision
MSL Altitude	63.8	meters	
Units	M	meters	
Geoid Separation	15.2	meters	
Units	M	meters	
Age of Diff. Corr.		second	Null fields when DGPS is not used
Diff. Ref. Station	ID 0000		
Checksum	*64		
<CR> <LF>			End of message termination

Table 3: Global Positioning System Fixed Data Example

Value	Description
0	Fix not available or invalid
1	GPS SPS Mode, fix valid
2	Differential GPS, SPS Mode, fix valid (Not Supported)
3-5	Not supported
6	Dead Reckoning Mode, fix valid

Table 4: Position Indicator Values

GLL – Geographic Position – Latitude / Longitude

The table below contains the values for the following example:

\$GPGLL,2503.6319,N,12136.0099,E,053740.000,A,A*52

Name	Example	Units	Description
Message ID	\$GPGLL		GLL protocol header
Latitude	2503.6319		ddmm.mmmm
N/S indicator	N		N=north or S=south
Longitude	12136.0099		dddmm.mmmm
E/W indicator	E		E=east or W=west
UTC Time	053740		hhmmss.sss
Status	A		A=data valid or V=data not valid
Mode	A		A=autonomous, D=DGPS
Checksum	*52		
<CR> <LF>			End of message termination

Table 5: Geographic Position – Latitude / Longitude Example

GSA – GNSS DOP and Active Satellites

The table below contains the values for the following example:

\$GPGSA,A,3,24,07,17,11,28,08,20,04,,,,,2.0,1.1,1.7*35

Name	Example	Units	Description
Message ID	\$GPGSA		GSA protocol header
Mode1	A		See Table 7
Mode 2	3		1=No Fix, 2=2D, 3=3D
ID of satellite used	24		Sv on Channel 1
ID of satellite used	7		Sv on Channel 2
...			...
ID of satellite used			Sv on Channel 12
PDOP	2		Position Dilution of Precision
HDOP	1.1		Horizontal Dilution of Precision
VDOP	1.7		Vertical Dilution of Precision
Checksum	*35		
<CR> <LF>			End of message termination

Table 6: GNSS DOP and Active Satellites Example

Value	Description
M	Manual - forced to operate in 2D or 3D mode
A	Automatic - allowed to automatically switch 2D/3D

Table 7: Mode1 Values

GSV – GNSS Satellites in View

The table below contains the values for the following example:

\$GPGSV,3,1,12,28,81,285,42,24,67,302,46,31,54,354,,20,51,077,46*73
 \$GPGSV,3,2,12,17,41,328,45,07,32,315,45,04,31,250,40,11,25,046,41*75
 \$GPGSV,3,3,12,08,22,214,38,27,08,190,16,19,05,092,33,23,04,127,*7B

Name	Example	Units	Description
Message ID	\$GPGSV		GSV protocol header
Total number of messages ¹	3		Range 1 to 3
Message number ¹	1		Range 1 to 3
Satellites in view	12		
Satellite ID	28		Channel 1 (Range 01 to 32)
Elevation	81	degrees	Channel 1 (Range 00 to 90)
Azimuth	285	degrees	Channel 1 (Range 000 to 359)
SNR (C/No)	42	dB-Hz	Channel 1 (Range 00 to 99, null when not tracking)
Satellite ID	20		Channel 4 (Range 01 to 32)
Elevation	51	degrees	Channel 4 (Range 00 to 90)
Azimuth	77	degrees	Channel 4 (Range 000 to 359)
SNR (C/No)	46	dB-Hz	Channel 4 (Range 00 to 99, null when not tracking)
Checksum	*73		
<CR> <LF>			End of message termination

Table 8: GNSS Satellites in View Example

1. Depending on the number of satellites tracked, multiple messages of GSV data may be required.

RMC – Recommended Minimum Specific GNSS Data

The table below contains the values for the following example:

`$GPRMC,053740.000,A,2503.6319,N,12136.0099,E,2.69,79.65,100106,,A*53`

Name	Example	Units	Description
Message ID	\$GPRMC		RMC protocol header
UTC Time	53740		hhmmss.sss
Status	A		A=data valid or V=data not valid
Latitude	2503.632		ddmm.mmmm
N/S Indicator	N		N=north or S=south
Longitude	12136.01		dddmm.mmmm
E/W Indicator	E		E=east or W=west
Speed over ground	2.69	knots	TRUE
Course over ground	79.65	degrees	
Date	100106		ddmmyy
Magnetic Variation		degrees	Not Available, Null Field
Variation Sense			E=east or W=west (Not shown)
Mode	A		A=autonomous, D=DGPS, E=DR
Checksum	*53		
<CR> <LF>			End of message termination

Table 9: Recommended Minimum Specific GNSS Data Example

VTG – Course Over Ground and Ground Speed

The table below contains the values for the following example:

`$GPVTG,79.65,T,,M,2.69,N,5.0,K,A*38`

Name	Example	Units	Description
Message ID	\$GPVTG		VTG protocol header
Course over ground	79.65	degrees	Measured heading
Reference	T		TRUE
Course over ground		degrees	Measured heading (N/A, Null Field)
Reference	M		Magnetic
Speed over ground	2.69	knots	Measured speed
Units	N		Knots
Speed over ground	5	km/hr	Measured speed
Units	K		Kilometer per hour
Mode	A		A=autonomous, E=DR
Checksum	*38		
<CR> <LF>			End of message termination

Table 10: Course Over Ground and Ground Speed Example

NMEA INPUT MESSAGES

The following outlines the serial commands input into the module for configuration. By default, the commands are input at 9,600bps, 8 data bits, no parity, and 1 stop bit.

Name	Example	Description
Start Sequence	\$PSRF	
Message ID	<MID>	Message Identifier consisting of three numeric characters. Input messages begin at MID 100.
Payload	DATA	Message specific data.
Checksum	CKSUM	CKSUM is a two-hex character checksum as defined in the NMEA specification, NMEA-0183 Standard For Interfacing Marine Electronic Devices. Checksums are required on all input messages.
End Sequence	<CR><LF>	Each message must be terminated using Carriage Return (CR) Line Feed (LF) (\r\n, 0x0D0A) to cause the receiver to process the input message. They are not printable ASCII characters, so are omitted from the examples.

Table 11: Serial Data Structure

All fields in all proprietary NMEA messages are required; none are optional. All NMEA messages are comma delimited.

The table below outlines the message identifiers supported by the module.

Message	MID	Description
SetSerialPort	100	Set PORT A parameters and protocol
NavigationInitialization	101	Reset the modules
Query/Rate Control	103	Query standard NMEA message and/or set output rate
LLANavigationInitialization	104	Reset the modules
Development Data On/Off	105	Development Data messages On/Off
PowerManagement	200	Sets the power performance of the receiver
StaticNavigation	202	Sets static navigation On/Off
SetIO	211	Sets the I/O lines to an input or output
ReadInput	212	Reads the state of the inputs lines
WriteOutput	213	Writes the state of an output line
Query	215	Get configuration and current state of all GPIOs

Table 12: Message ID Values

100 – SetSerialPort

This command message is used to set the protocol (SiRF binary or NMEA) and/or the communication parameters (baud rate). Generally, this command is used to switch the module back to SiRF binary protocol mode where a more extensive command message set is available. When a valid message is received, the parameters are stored in battery-backed SRAM and the receiver restarts using the saved parameters.

The table below contains the values for the following example:

Switch to SiRF binary protocol at 9600,8,N,1

*\$PSRF100,0,9600,8,1,0*0C*

Name	Example	Description
Message ID	\$PSRF100	PSRF100 protocol header
Protocol	0	0=SiRF binary, 1=NMEA
Baud	9600	4800, 9600, 19200, 38400, 57600
DataBits	8	8 ¹
StopBits	1	1 ¹
Parity	0	0=None ¹
Checksum	*0C	
<CR><LF>		End of message termination

Table 13: SetSerialPort Example ²

1. SiRF protocol is only valid for 8 data bits, 1 stop bit, and no parity.
2. Default settings are NMEA protocol using 9,600 baud, 8 data bits, 1 stop bit, and no parity.

For details on the SiRF binary protocol, please refer to SiRF's Binary Protocol Reference Manual.

101 – NavigationInitialization

This command was used to initialize the receiver with the current position (in X, Y, Z coordinates), clock offset, and time, enabling a faster fix. Increased receiver sensitivity and the removal of Selective Availability (SA) have made this unnecessary. The command is retained for its ability to reset the module, but the initialization fields are no longer supported.

The table below contains the values for the following example:

*\$PSRF101,0,0,0,96000,0,0,12,4*1F*

Name	Example	Units	Description
Message ID	\$PSRF101		PSRF101 protocol header
ECEF X	0		
ECEF Y	0		
ECEF Z	0		
ClkOffset	96000		
TimeOfWeek	0		
WeekNo	0		
ChannelCount	12		
ResetCfg	4		See Table 15
Checksum	*1F		
<CR><LF>			End of message termination

Table 14: NavigationInitialization Example

Hex	Description
0x01	Hot Start – All data valid
0x02	Warm Start – Ephemeris cleared
0x04	Cold Start – Clears all data in memory
0x08	Clear Memory – Clears all data in memory and resets the receiver back to factory defaults

Table 15: ResetCfg Values

103 – Query/Rate Control

This command is used to control the output of standard NMEA messages GGA, GLL, GSA, GSV, RMC, and VTG. Using this command message, standard NMEA messages may be polled once, or setup for periodic output. Checksums may also be enabled or disabled depending on the needs of the receiving program. NMEA message settings are saved in battery-backed memory for each entry when the message is accepted.

The table below contains the values for the following example:

1. Query the GGA message with checksum enabled

\$PSRF103,00,01,00,01*25

2. Enable VTG message for a 1 Hz constant output with checksum enabled

\$PSRF103,05,00,01,01*20

3. Disable VTG message

\$PSRF103,05,00,00,01*21

Name	Example	Units	Description
Message ID	\$PSRF103		PSRF103 protocol header
Msg	0		See Table 17
Mode	1		0=SetRate, 1=Query
Rate	0	seconds	Output – off=0, max=255
CksumEnable	1		0=Disable, 1=Enable Checksum
Checksum	*25		
<CR><LF>			End of message termination

Table 16: Query/Rate Control Example ¹

Value	Description
0	GGA
1	GLL
2	GSA
3	GSV
4	RMC
5	VTG
6	MSS (Not Supported)
7	Not defined
8	ZDA
9	Not defined

Table 17: MSG Values

1. Default setting is GGA, GLL, GSA, GSV, RMC, and VTG NMEA messages are enabled with checksum at a rate of 1 second.

104 – LLANavigationInitialization

This command was used to initialize the receiver with the current position (in latitude, longitude and altitude coordinates), clock offset, and time, enabling a faster fix. Increased receiver sensitivity and the removal of Selective Availability (SA) have made this unnecessary. The command is retained for its ability to reset the module, but the initialization fields are no longer supported.

The table below contains the values for the following example:

\$PSRF104,0,0,0,96000,0,0,12,4*1A

Name	Example	Units	Description
Message ID	\$PSRF104		PSRF104 protocol header
Latitude	0		
Longitude	0		
Altitude	0		
ClkOffset	96000		
TimeOfWeek	0		
WeekNo	0		
ChannelCount	12		
ResetCfg	4		See Table 19
Checksum	*1A		
<CR><LF>			End of message termination

Table 18: LLANavigationInitialization Example

Hex	Description
0x01	Hot Start – All data valid
0x02	Warm Start – Ephemeris cleared
0x04	Cold Start – Clears all data in memory
0x08	Clear Memory – Clears all data in memory and resets receiver back to factory defaults

Table 19: ResetCfg Values

105 – Development Data On/Off

Use this command to enable development data information if you are having trouble getting commands accepted. Invalid commands generate debug information that enables you to determine the source of the command rejection. Common reasons for input command rejection are invalid checksum or parameter out of specified range.

The table below contains the values for the following example:

1. Debug On

*\$PSRF105,1*3E*

2. Debug Off

*\$PSRF105,0*3F*

Name	Example	Units	Description
Message ID	\$PSRF105		PSRF105 protocol header
Debug	1		0=Off, 1=On
Checksum	*3E		
<CR><LF>			End of message termination

Table 20: Development Data On/Off Example¹

1. Default setting is debug mode off.

200 – PowerManagement

The table below contains the values for the following example to set the receiver to Adaptive Trickle Power mode:

*\$PLSC,200,2,300,1000,300000,30000*0E*

Name	Example	Units	Description
MID	<i>\$PLSC,200</i>		Message ID
Mode	2		See Table 22
OnTime	300 (200 - 900)	mS	Must be ≥ 200 mS and a multiple of 100 (if not, it is rounded up to the nearest multiple of 100).
LP Interval	1000 (1000 - 10000)	mS	Must be an integer value ≥ 1000 and ≤ 10000 .
MaxAcqTime	300000 (1000 - 2147483000)	mS	When Adaptive Trickle Power is enabled, this is the maximum allowable time from the start of a power cycle to the time a valid position fix is obtained. If no fix is obtained in this time, the receiver is deactivated for up to MaxOffTime, and a hot start is commanded when the receiver reactivates. The integer must be in multiples of 1000mS.
MaxOffTime	30000 (1000 - 1800000)	mS	The longest period (in mS) for which the receiver deactivates due to the MaxAcqTime timeout. The actual deactivated period may be less if the user-specified duty cycle (OnTime / LpInterval) can be maintained.
Checksum	*0E		
<CR> <LF>			End of message termination

Table 21: Power Management Command Example¹

The table below lists the possible values for the Mode section of this command.

Value	Description
0	Ask receiver to send current power mode
1	Set receiver to Full power mode
2	Set receiver to Adaptive Trickle Power mode

Table 22: Mode Values

Total ON time = OnTime + 160mS + time to process each active NMEA message at the programmed baud rate (default 9600)

1. Default setting is full power; trickle power disabled.

The receiver outputs a response to this command. The table below contains the response for the above command:

*\$PLSR,200,1,2,300,1000,300000,30000*02*

Name	Example	Units	Description
MID	\$PLSR,200		Message ID
Valid	1		0: command invalid, 1: command valid
Mode	2		See Table 22
OnTime	300		Display when mode = 2
LP Interval	1000		Display when mode = 2
MaxAcqTime	300000		Display when mode = 2
MaxOffTime	30000		Display when mode = 2
Checksum	*02		
<CR> <LF>			End of message termination

Table 23: Power Management Response Example

For some further examples of this command:

- Query the power management mode
Input command: \$PLSC,200,0*0E
Output response: \$PLSR,200,1,1*03

202 – StaticNavigation

This command is used to query, enable, and disable static navigation. The table below contains the values for the following example to disable static navigation:

*\$PLSC,202,2*0E*

Name	Example	Units	Description
MID	\$PLSR,202		Message ID
Command	1		0: Query, 1: Enable (default), 2: Disable
Checksum	*02		
<CR> <LF>			End of message termination

Table 24: StaticNavigation Example

The table below contains the response for the above command:

Name	Example	Units	Description
MID	\$PLSR,202		Message ID
Valid	1		0: command invalid, 1: command valid
Result	2		0: command failed, 1: static navigation enabled, 2: static navigation disabled
Checksum	*1E		
<CR> <LF>			End of message termination

Table 25: StaticNavigation Response Example

211 – SetIO

The table below contains the values for the following example to set GPIO 1 as an input:

*\$PLSC,211,1,0,0*0F*

Name	Example	Units	Description
MID	\$PLSC,211		Message ID
GPIO Number	1		Number of the GPIO line to set. Only one line can be set at a time.
Direction	0		Direction; 0 = Input; 1 = Output
State	0		Set to 1 if the direction is an output; the value does not matter if the direction is an input.
Checksum	*0F		
<CR> <LF>			End of message termination

Table 26: SetIO Example

The receiver outputs a response to this command. The table below contains the response for the above command:

Name	Example	Units	Description
MID	\$PLSR,211		Message ID
Valid	1		0: command invalid, 1: command valid
Checksum	*1E		
<CR> <LF>			End of message termination

Table 27: SetIO Response Example

For some further examples of this command:

- Set GPIO 1 as an Input
Input command: \$PLSC,211,1,0,0*0F
Output response: \$PLSR,211,1*1E
- Set GPIO 1 as an output, initial state low
Input command: \$PLSC,211,1,1,0*0E
Output response: \$PLSR,211,1*1E

NOTE

1. If the message ID is not recognized, the response will be "\$PLSR,999,0,ERROR*60"
2. If the value is not allowed, the response will be "\$PLSR,MID,0,ERROR*CS"
3. All GPIOs default to inputs on power-up and reset.

212 – ReadInput

The table below contains the values for the following example to read the state of an input:

*\$PLSC,212,1*0C*

Name	Example	Units	Description
MID	<i>\$PLSC,212</i>		Message ID
GPIO Number	1		Number of the GPIO line to read. Only one line can be set at a time.
Checksum	*0C		
<CR> <LF>			End of message termination

Table 28: ReadInput Example

The receiver outputs a response to this command. The table below contains the response for the above command:

Name	Example	Units	Description
MID	<i>\$PLSR,212</i>		Message ID
GPIO Number	1		Number of the GPIO line to set. Only one line can be set at a time.
State	0		0 = Low; 1 = High; 2 = the referenced GPIO is not an input
Checksum	*01		
<CR> <LF>			End of message termination

Table 29: ReadInput Response Example

For some further examples of this command:

- Read that GPIO 1 is low
Input command: *\$PLSC,212,1*0C*
Output response: *\$PLSR,212,1,0*01*
- Read that GPIO 1 is high
Input command: *\$PLSC,212,1*0C*
Output response: *\$PLSR,212,1,1*00*
- Read that GPIO 1 is not an input
Input command: *\$PLSC,212,1*0C*
Output response: *\$PLSR,212,1,2*03*

213 – WriteOutput

The table below contains the values for the following example to write the state of GPIO 1 to low:

*\$PLSC,213,1,0*11*

Name	Example	Units	Description
MID	<i>\$PLSC,213</i>		Message ID
GPIO Number	1		Number of the GPIO line to write. Only one line can be set at a time.
State	0		State; 0 = Low; 1 = High
Checksum	*11		
<CR> <LF>			End of message termination

Table 30: WriteOutput Example

The receiver outputs a response to this command. The table below contains the response for the above command:

Name	Example	Units	Description
MID	<i>\$PLSR,213</i>		Message ID
Valid	1		0: command invalid, 1: command valid
Checksum	*1C		
<CR> <LF>			End of message termination

Table 31: WriteOutput Response Example

For some further examples of this command:

- Set GPIO 1 to low
Input command: *\$PLSC,213,1,0*11*
Output response: *\$PLSR,213,1*1C*
- Set GPIO 1 to high
Input command: *\$PLSC,213,1,1*10*
Output response: *\$PLSR,213,1*1C*
- GPIO 1 is not an output
Input command: *\$PLSC,213,1,1*10*
Output response: *\$PLSR,213,0*1D*

215 – Query

The table below contains the values for the following example to read the configuration and state of all of the GPIO lines:

`$PLSC,215*16`

Name	Example	Units	Description
MID	<code>\$PLSC,215</code>		Message ID
Checksum	<code>*16</code>		
<CR> <LF>			End of message termination

Table 32: Query Example

The receiver outputs a response to this command. The table below contains the response for the above command:

Name	Example	Units	Description
MID	<code>\$PLSR,215</code>		Message ID
Count	5		Total number of GPIOs
GPIO Number	1		GPIO Number
Configuration	0		Direction; 0 = Input; 1 = Output
Current State	0		0 = Low; 1 = High
GPIO Number	10		GPIO Number
Configuration	0		Direction; 0 = Input; 1 = Output
Current State	1		0 = Low; 1 = High
GPIO Number	13		GPIO Number
Configuration	0		Direction; 0 = Input; 1 = Output
Current State	1		0 = Low; 1 = High
GPIO Number	14		GPIO Number
Configuration	0		Direction; 0 = Input; 1 = Output
Current State	1		0 = Low; 1 = High
GPIO Number	15		GPIO Number
Configuration	0		Direction; 0 = Input; 1 = Output
Current State	1		0 = Low; 1 = High
Checksum	<code>*00</code>		
<CR> <LF>			End of message termination

Table 33: Query Response Example

For some further examples of this command:

- Set GPIO 1 to low

Input command: `$PLSC,215*16`

Output response: `$PLSR,215,5,1,0,0,10,0,1,13,0,1,14,0,1,15,0,1*00`

MASTER DEVELOPMENT SYSTEM

The SG Series Master Development System provides all of the tools necessary to evaluate the SG Series GPS receiver module. The system includes a fully assembled development board, an active antenna, development software, and full documentation.



Figure 6: The SG Series Master Development System

The development board includes a power supply, a prototyping area for custom circuit development, and an OLED display that shows the GPS data without the need for a computer. A USB interface is also included for use with a PC running custom software or the included development software.

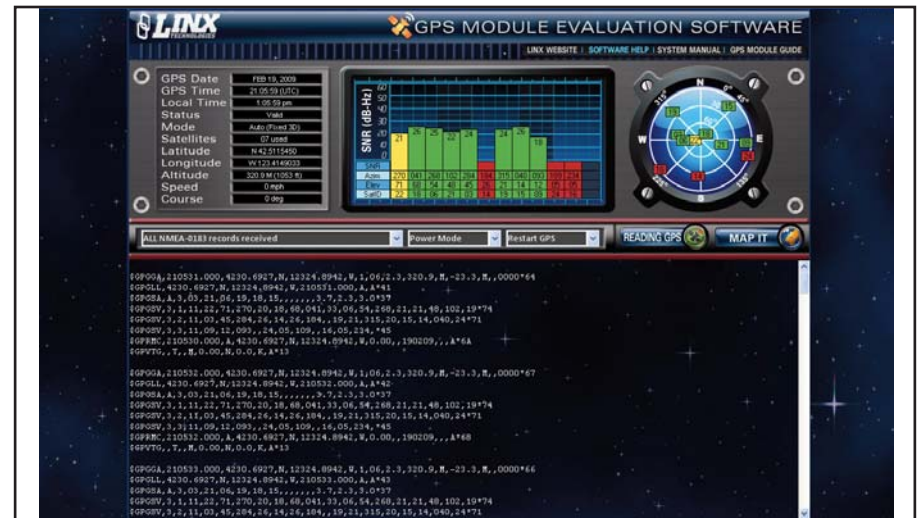

Figure 7: The SG Series Master Development System Software

The Master Development System software enables configuration of the receiver and displays the satellite data output by the receiver. The software can select from among all of the supported NMEA protocols for display of the data.

Full documentation for the board and software is included in the development system, making integration of the module straightforward.

BOARD LAYOUT GUIDELINES

The module's design makes integration straightforward; however, it is still critical to exercise care in PCB layout. Failure to observe good layout techniques can result in a significant degradation of the module's performance. A primary layout goal is to maintain a characteristic 50-ohm impedance throughout the path from the antenna to the module. Grounding, filtering, decoupling, routing and PCB stack-up are also important considerations for any RF design. The following section provides some basic design guidelines which may be helpful.

During prototyping, the module should be soldered to a properly laid-out circuit board. The use of prototyping or "perf" boards will result in poor performance and is strongly discouraged.

The module should, as much as reasonably possible, be isolated from other components on your PCB, especially high-frequency circuitry such as crystal oscillators, switching power supplies, and high-speed bus lines.

When possible, separate RF and digital circuits into different PCB regions. Make sure internal wiring is routed away from the module and antenna, and is secured to prevent displacement.

Do not route PCB traces directly under the module. There should not be any copper or traces under the module on the same layer as the module, just bare PCB. The underside of the module has traces and vias that could short or couple to traces on the product's circuit board.

The Pad Layout section shows a typical PCB footprint for the module. A ground plane (as large and uninterrupted as possible) should be placed on a lower layer of your PC board opposite the module. This plane is essential for creating a low impedance return for ground and consistent stripline performance.

Use care in routing the RF trace between the module and the antenna or connector. Keep the trace as short as possible. Do not pass under the module or any other component. Do not route the antenna trace on multiple PCB layers as vias will add inductance. Vias are acceptable for tying together ground layers and component grounds and should be used in multiples.

Each of the module's ground pins should have short traces tying immediately to the ground plane through a via.

Bypass caps should be low ESR ceramic types and located directly adjacent to the pin they are serving.

A 50-ohm coax should be used for connection to an external antenna. A 50-ohm transmission line, such as a microstrip, stripline or coplanar waveguide should be used for routing RF on the PCB. The Microstrip Details section provides additional information.

In some instances, a designer may wish to encapsulate or "pot" the product. There is a wide variety of potting compounds with varying dielectric properties. Since such compounds can considerably impact RF performance and the ability to rework or service the product, it is the responsibility of the designer to evaluate and qualify the impact and suitability of such materials.

MICROSTRIP DETAILS

A transmission line is a medium whereby RF energy is transferred from one place to another with minimal loss. Common forms of transmission lines are coax cable, microstrip, stripline, and coplanar waveguides. Since a microstrip is straightforward to understand we will focus on it here. Other forms of transmission lines may also be utilized.

The term "microstrip" refers to a PCB trace running over a ground plane that is designed to serve as a transmission line. The width of the trace is based on the desired characteristic impedance of the line (in this case 50 ohms), the thickness of the PCB, and the dielectric constant of the board material. For standard 0.062in thick FR-4 board material, the trace width would be 111 mils. The correct trace width can be calculated for other widths and materials using the information below. Handy software for calculating microstrip lines is also available on the Linx website, www.linxtechnologies.com. There is also a variety of free programs and design tools available from other sources which can be found readily on the internet.

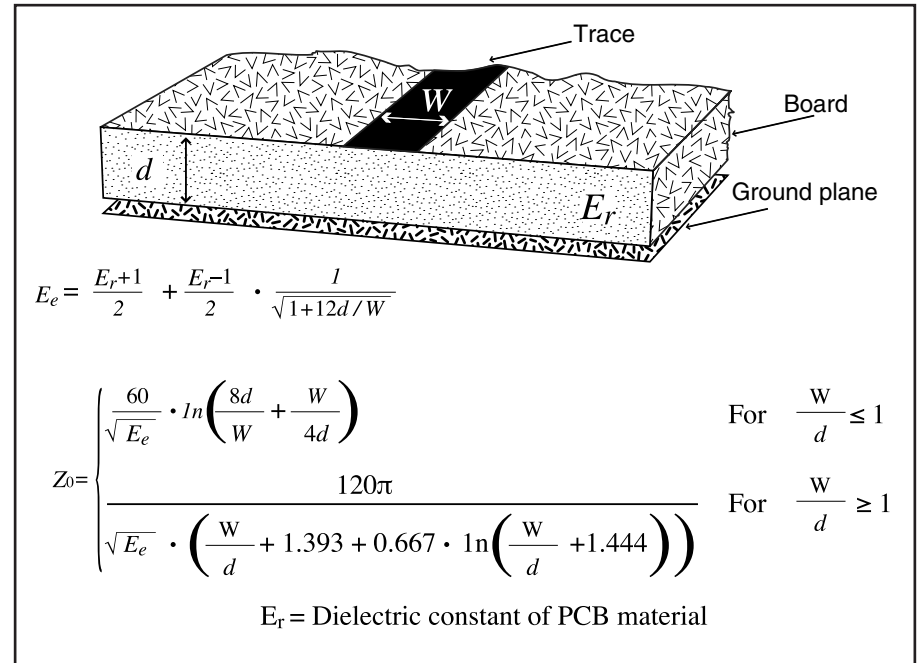

Figure 8: Microstrip Formulas

Dielectric Constant	Width/Height (W/d)	Effective Dielectric Constant	Characteristic Impedance
4.80	1.8	3.59	50.0
4.00	2.0	3.07	51.0
2.55	3.0	2.12	48.0

PAD LAYOUT

The following pad layout diagram is designed to facilitate both hand and automated assembly.

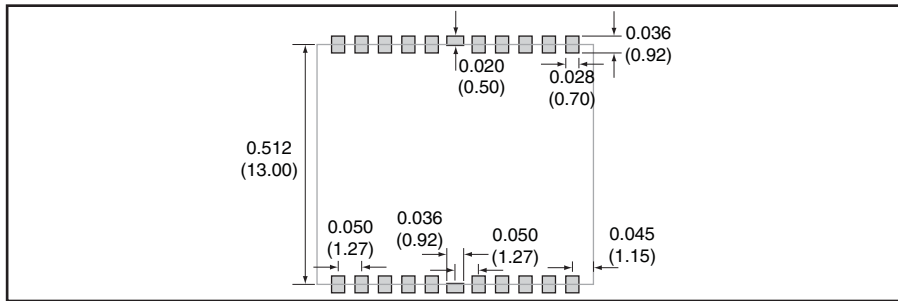

Figure 9: Recommended PCB Layout

PRODUCTION GUIDELINES

The modules are housed in a hybrid SMD package that supports hand and automated assembly techniques. Since the modules contain discrete components internally, the assembly procedures are critical to ensuring the reliable function of the modules. The following procedures should be reviewed with and practiced by all assembly personnel.

HAND ASSEMBLY

Pads located on the bottom of the module are the primary mounting surface. Since these pads are inaccessible during mounting, castellations that run up the side of the module have been provided to facilitate solder wicking to the module's underside. This allows for very quick hand soldering for prototyping and small volume production.

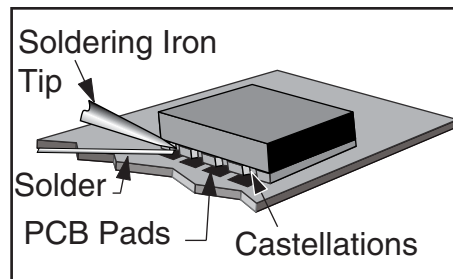

Figure 10: Soldering Technique

If the recommended pad guidelines have been followed, the pads will protrude slightly past the edge of the module. Use a fine soldering tip to heat the board pad and the castellation, then introduce solder to the pad at the module's edge. The solder will wick underneath the module, providing reliable attachment. Tack one module corner first and then work around the device, taking care not to exceed the times listed below.

Absolute Maximum Solder Times

Hand-Solder Temp. TX +225°C for 10 Seconds

Hand-Solder Temp. RX +225°C for 10 Seconds

Recommended Solder Melting Point +180°C

Reflow Oven: +240°C Max. (See adjoining diagram)

AUTOMATED ASSEMBLY

For high-volume assembly, most users will want to auto-place the modules. The modules have been designed to maintain compatibility with reflow processing techniques; however, due to their hybrid nature, certain aspects of the assembly process are far more critical than for other component types.

Following are brief discussions of the three primary areas where caution must be observed.

Reflow Temperature Profile

The single most critical stage in the automated assembly process is the reflow stage. The reflow profile below should not be exceeded, since excessive temperatures or transport times during reflow will irreparably damage the modules. Assembly personnel will need to pay careful attention to the oven's profile to ensure that it meets the requirements necessary to successfully reflow all components while still remaining within the limits mandated by the modules. The figure below shows the recommended reflow oven profile for the modules.

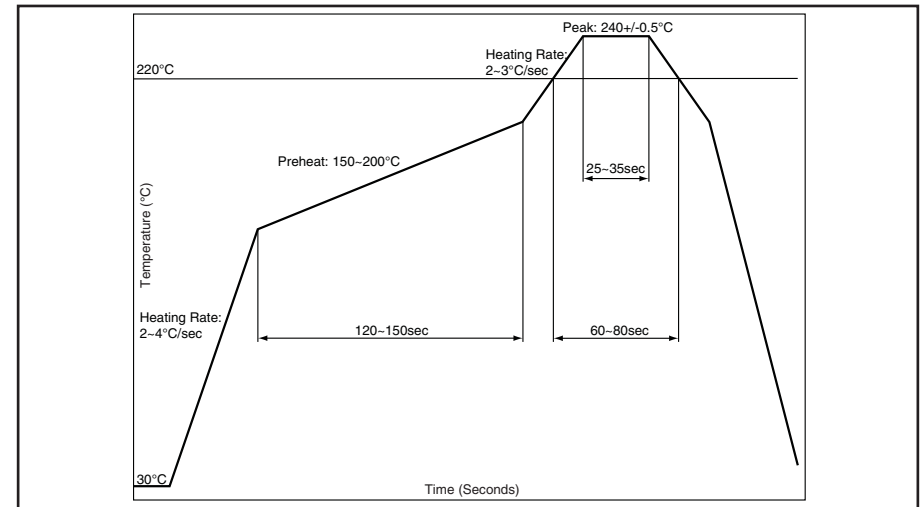

Figure 11: Maximum Reflow Profile

Shock During Reflow Transport

Since some internal module components may reflow along with the components placed on the board being assembled, it is imperative that the modules not be subjected to shock or vibration during the time solder is liquid. Should a shock be applied, some internal components could be lifted from their pads, causing the module to not function properly.

Washability

The modules are not hermetically sealed. Linx recommends wash-free manufacturing; however, the modules can be subjected to a wash cycle provided that a drying time is allowed prior to applying electrical power to the modules. The drying time should be sufficient to allow any moisture that may have migrated into the module to evaporate, thus eliminating the potential for shorting damage during power-up or testing. If the wash contains contaminants, the performance may be adversely affected, even after drying.



U.S. CORPORATE HEADQUARTERS

LINX TECHNOLOGIES, INC.

**159 ORT LANE
MERLIN, OR 97532**

**PHONE: (541) 471-6256
FAX: (541) 471-6251
www.linxtechnologies.com**

Disclaimer

Linx Technologies is continually striving to improve the quality and function of its products. For this reason, we reserve the right to make changes to our products without notice. The information contained in this Data Guide is believed to be accurate as of the time of publication. Specifications are based on representative lot samples. Values may vary from lot-to-lot and are not guaranteed. "Typical" parameters can and do vary over lots and application. Linx Technologies makes no guarantee, warranty, or representation regarding the suitability of any product for use in any specific application. It is the customer's responsibility to verify the suitability of the part for the intended application. **NO LINX PRODUCT IS INTENDED FOR USE IN ANY APPLICATION WHERE THE SAFETY OF LIFE OR PROPERTY IS AT RISK.**

Linx Technologies **DISCLAIMS ALL WARRANTIES OF MERCHANTABILITY AND FITNESS FOR A PARTICULAR PURPOSE. IN NO EVENT SHALL LINX TECHNOLOGIES BE LIABLE FOR ANY OF CUSTOMER'S INCIDENTAL OR CONSEQUENTIAL DAMAGES ARISING IN ANY WAY FROM ANY DEFECTIVE OR NON-CONFORMING PRODUCTS OR FOR ANY OTHER BREACH OF CONTRACT BY LINX TECHNOLOGIES.** The limitations on Linx Technologies' liability are applicable to any and all claims or theories of recovery asserted by Customer, including, without limitation, breach of contract, breach of warranty, strict liability, or negligence. Customer assumes all liability (including, without limitation, liability for injury to person or property, economic loss, or business interruption) for all claims, including claims from third parties, arising from the use of the Products. The Customer will indemnify, defend, protect, and hold harmless Linx Technologies and its officers, employees, subsidiaries, affiliates, distributors, and representatives from and against all claims, damages, actions, suits, proceedings, demands, assessments, adjustments, costs, and expenses incurred by Linx Technologies as a result of or arising from any Products sold by Linx Technologies to Customer. Under no conditions will Linx Technologies be responsible for losses arising from the use or failure of the device in any application, other than the repair, replacement, or refund limited to the original product purchase price. Devices described in this publication may contain proprietary, patented, or copyrighted techniques, components, or materials. Under no circumstances shall any user be conveyed any license or right to the use or ownership of such items.

Mouser Electronics

Authorized Distributor

Click to View Pricing, Inventory, Delivery & Lifecycle Information:

[Linx Technologies:](#)

[RXM-GPS-SG-B](#)